

Upgrade of the endoscopic optical system installed on the T-10 tokamak. The first experimental results

E.O. Kuleshin, A.A. Medvedev, V.A. Vershkov, D.K. Vukolov

National Research Centre "Kurchatov Institute", Moscow, Russian Federation

This paper describes upgrade of the endoscopic optical system installed on the T-10 tokamak and the first experimental results obtained after this modernization. This endoscopic optical system makes possible an investigation of the particles balance in plasma, which is an important topic in the physics of tokamaks.

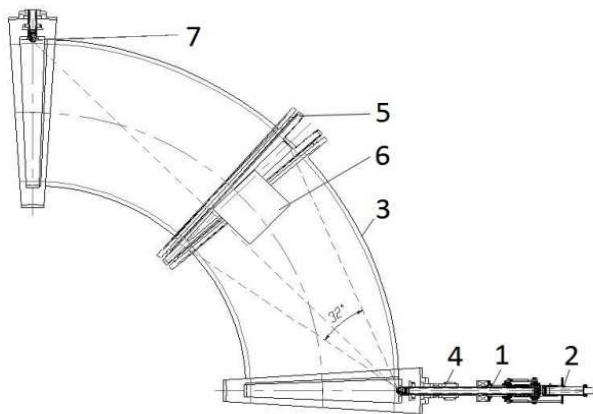

Fig.1. Arrangement of the endoscope.

Geometry of the observation..

1 – vacuum part; 2 – atmospheric part; 3 – vacuum vessel; 4 – diagnostic port; 5 – aperture limiter; 6 – rail movable limiter; 7 – gas valve.

There are two limiters situated in the vacuum vessel of the T-10 tokamak. It is the aperture limiter having a shape of a ring with an inner diameter of about 34 cm, and the rail movable limiter.

The location of the described system (Fig.1) allows the tangential observation of the vacuum vessel cross-section where the graphite limiters and the gas valve are situated (Fig.2).

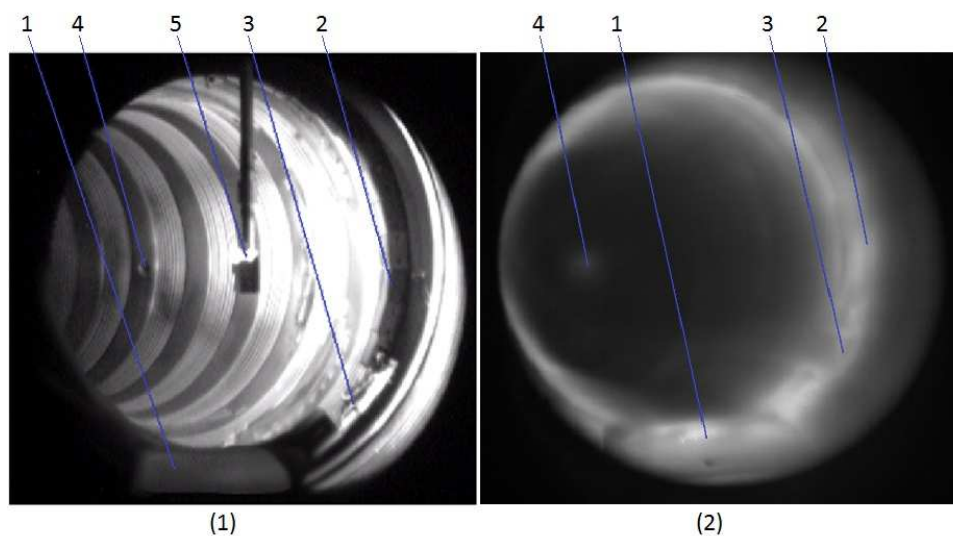

Fig.2. Field of view of the endoscope without the plasma (1) and during a discharge (2).

1 - rail movable limiter; 2 - aperture limiter; 3 - stay-bolt; 4 - gas valve; 5 - backlight.

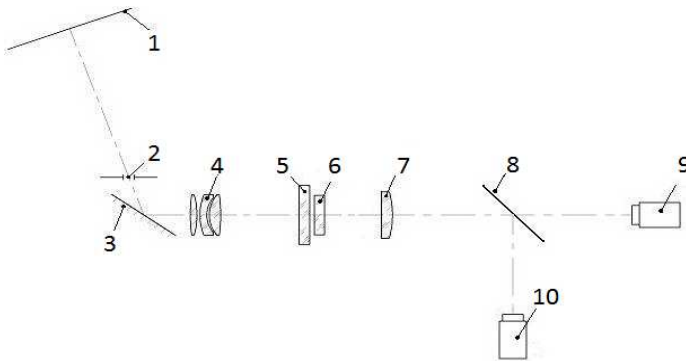

Fig.3. Optical scheme of the endoscope after the upgrade.

- 1 - object; 2 - aperture; 3 - first mirror; 4 - input lens;
- 5 - porthole; 6 - narrowband filter; 7 - output lens;
- 8 - beamsplitter; 9 - IR-camera; 10 - high-speed camera.

Simultaneous use of two detectors in order to monitor limiter region of the tokamak in the visible and near IR spectral region was provided in consequence of the modernization (Fig.3). High-speed video camera is used for operation in the visible spectral region. This camera is characterised by a temporal resolution from 250 μ s to 100 ms.

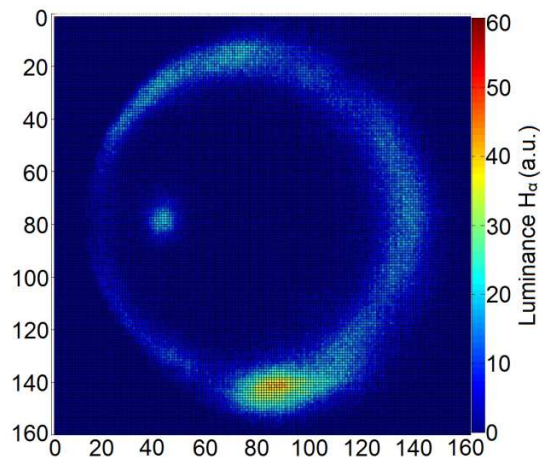

Fig.4. Luminance of the plasma radiation at H_α

Luminance of the plasma radiation in the field of the valve is easily separable from the luminance of the plasma radiation in the field of the limiters due to successful choice of diagnostic location (Fig.4). This enabled to perform calibration of the diagnostic to determine absolute deuterium neutrals influx into the plasma.

line when the valve is open.

The value of deuterium neutrals influx from the valve was determined from the difference between the total number of particles,

defined according to the interferometer before and after switching off the valve (Fig.5). The maximum influx was determined from the increase of the total number of particles with the fully open valve, amounting to $4 \cdot 10^{20}$ particles per second (Fig.6). The obtained values of the

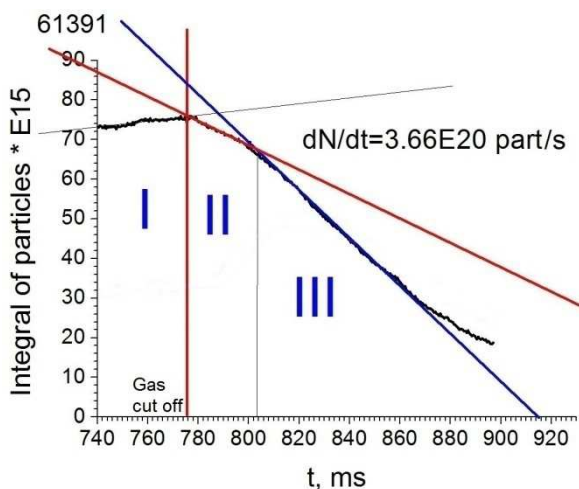

Fig.5. The total number of particles before and after switching off the valve.

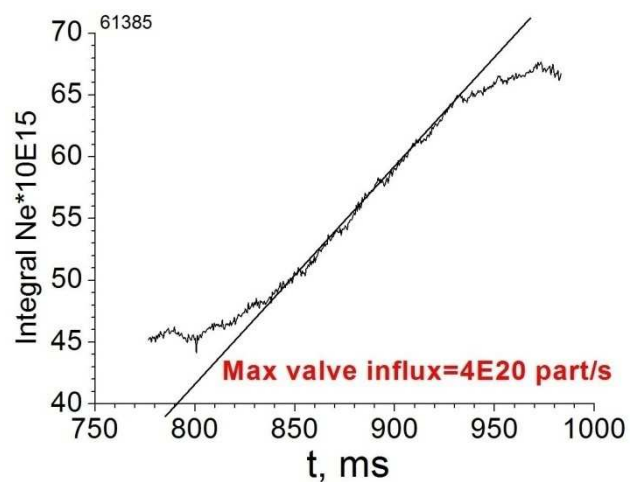

Fig.6. The total number of particles in the fully open valve.

deuterium influx were compared with the integral luminance of the plasma radiation at H_{α} line in the field of the valve. As a result, the diagnostic was calibrated. Correction coefficient $\kappa = 4$ has been introduced to determine the deuterium influx in the field of limiters. This coefficient takes into account the fact that the valve is two times farther of the limiters.

Analysis of the plasma radiation luminance at H_{α} line in the field of the limiters showed that the limiters are the main source of deuterium influx into the plasma. Moreover on the rail movable limiter accounts for about 20% and on the aperture limiter about 80% of the total deuterium influx from limiters.

Luminance of the plasma radiation at H_{α} line in the field of the limiters was investigated in the discharges with lithium gettering. Lithium gettering was carried out by a single evaporation of the lithium sample at the beginning of the day in the cross-section of the limiters. Recycling coefficient and absolute deuterium influx into the plasma from the limiters and the valve were estimated for each discharge. For example, deuterium influx from the valve was $3.7 \cdot 10^{20}$ particles per second for discharge No.61391 (the second discharge after lithium gettering). The integral luminance of the plasma radiation in the field of the limiters exceeded the integral luminance of the plasma radiation in the field of the valve to 6 times from 450 to 750 ms (Fig.7). Consequently, deuterium influx from the limiters was about $2.2 \cdot 10^{21}$ particles per second. Estimation of recycling coefficient after each discharge has shown that this method of lithium gettering has a main effect only about on the first 5 discharges (Fig.8).

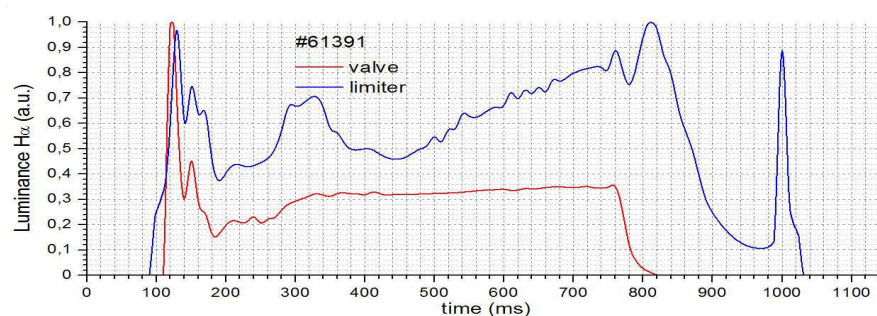

Fig.7. Luminance of the plasma radiation at H_{α} line in the field of valve and limiters in the discharge No.61391.

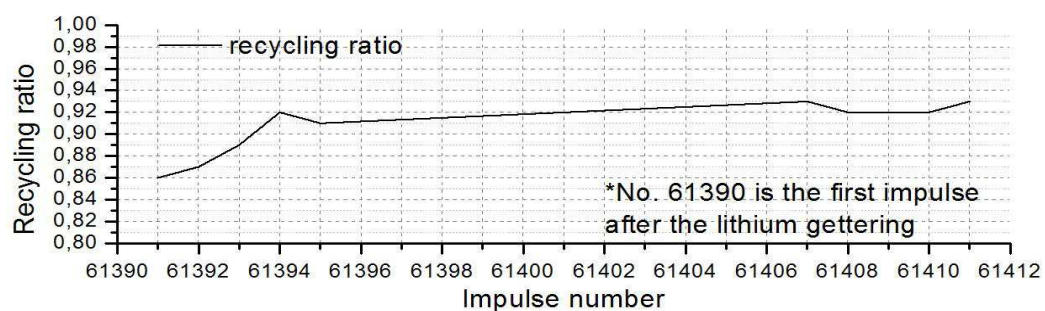

Fig.8. Recycling coefficients for discharges with lithium gettering.

The obtained data in the discharges with periodic gas valve shows that modulation of the influx from the valve modulates influx from limiters. Influx from the limiters falls by 10-15% when opening the valve and it comes back to the same level or increases when closing the valve (Fig.9). Thus, the real deuterium influx into the plasma can be a complex function of the influx from the valve.

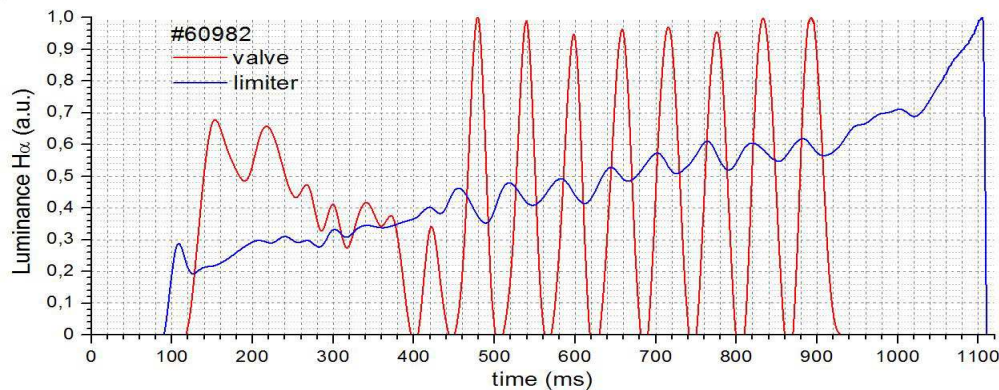

Fig.9. Luminance of the plasma radiation at H_{α} line in the discharge with periodic gas valve.

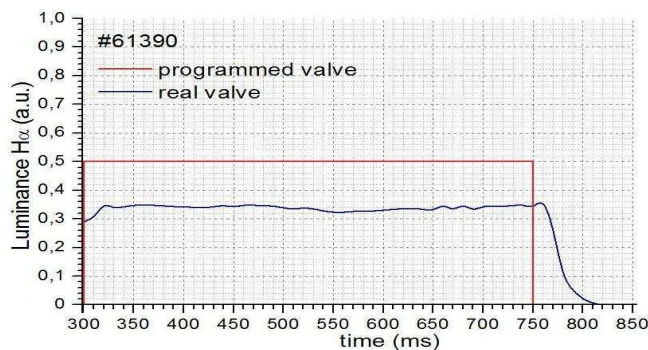

Fig.10. Luminance of the plasma radiation at H_{α} line in the field of valve.

Analysis of the work of the gas valve was carried out (Fig.10). Time delay between valve opening (feeding voltage on it) and gas influx into the plasma was defined and amounted to 10-15 ms. Time of gas leaking after closing the valve was also defined, amounting to about 30 ms.

The registration of the spatial distribution of the plasma radiation luminance was carried out on the T-10 tokamak during a plasma operation campaign. The possibility of using this diagnostic was shown in important programs for T-10. Recycling coefficient and absolute deuterium influx into the plasma, amounting to about $2.5-3 \cdot 10^{21}$ particles per second, were estimated in the discharges with lithium gettering. Uniform distribution of the plasma interaction with the limiters across their surface was observed in most of discharges. However, cases of strong localized heating of some parts of the limiters registered. These cases are observed most frequently in the discharges with an electron cyclotron resonance heating (ECRH). The importance of control of the limiters and the surrounding areas of the vacuum vessel as well as investigation of the particles balance in plasma was demonstrated by diagnostic.